

Model CPE/F z górnym (mocującym) hakiem,
pojedyncze ciągnie
1.600 - 3.000 kg

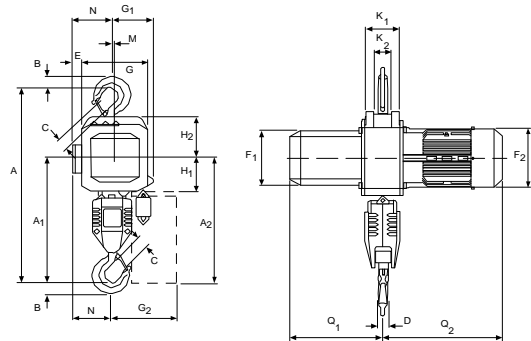

Model CPE/F z górnym (mocującym) hakiem,
podwójne ciągnie
3.200 - 5.000 kg

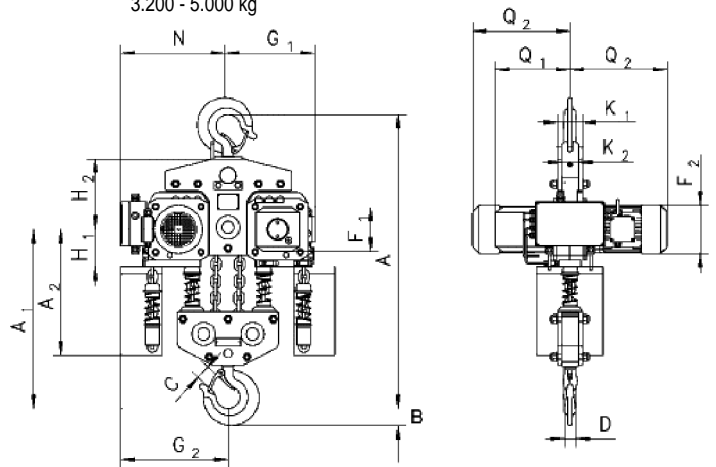

Model CPE/F 100-2 z górnym (mocującym) hakiem
10.000 kg

Wymiary modeli CPE/CPEF w mm

Wymiar	CPE/CPEF 16-8	CPE/CPEF 20-8	CPE/CPEF 25-5	CPE/CPEF 30-5	CPE/CPEF 32-4	CPE/CPEF 40-4	CPE/CPEF 50-2	CPE/CPEF 100-2
A	516	516	516	516	681	681	681	1068
A ₁	286	286	286	286	428	428	428	651
A ₂ (13 m)	430	430	430	430	430	430	430	-
A ₂ (21 m)	530	530	530	530	530	530	530	555
B	35	35	35	35	45	45	45	60
C	37	37	37	37	46	46	46	52
D	24	24	24	24	30	30	30	40/45
E	24	24	24	24	24	24	24	-
F ₁	160	160	160	160	160	160	160	160
F ₂	178	178	178	178	178	178	178	178
G	220	220	220	220	220	220	220	705
G ₁	180	180	180	180	140	140	140	315
G ₂ (13 m)	257	257	257	257	218	218	218	-
G ₂ (21 m)	277	277	277	277	238	238	238	408
H ₁	110	110	110	110	110	110	110	135
H ₂	135	135	135	135	135	135	135	256
K ₁	100	100	100	100	100	100	100	92
K ₂	51	51	51	51	51	51	51	62
M	50,0	50,0	50,0	50,0	9,6	9,6	9,6	-
N	84	84	84	84	124	124	124	390
Q ₁	272	272	272	272	272	272	272	272
Q ₂ (CPE)	362	362	362	362	362	362	362	362
Q ₂ (CPEF)	417	417	417	417	417	417	417	417



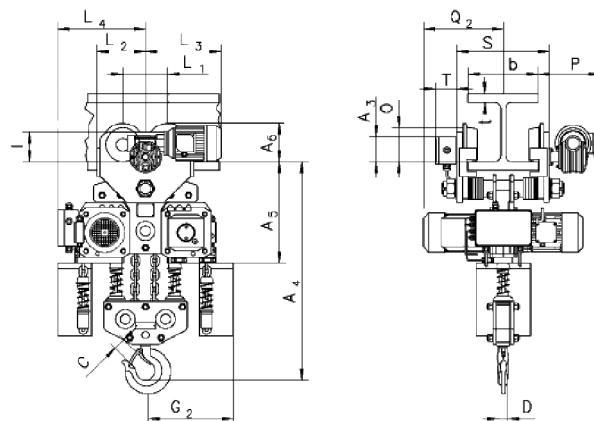
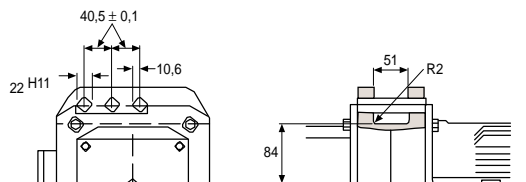

Model CPE/F 100-2, z zintegrowanym wózkiem elektrycznym
10.000 kg

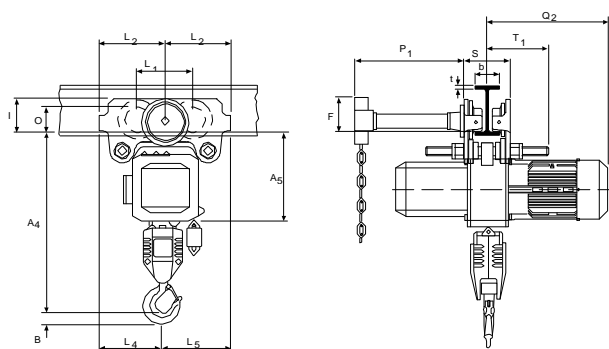

Model CPE/F
z zintegrowanym wózkiem jezdny pchanym/z zębatką

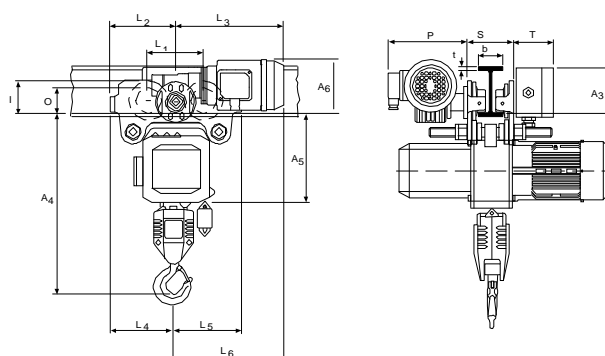

Model CPE/F
z zintegrowanym wózkiem elektrycznym

Wymiary modeli CPE/CPEF w mm

Wymiar	CPE/CPEF 16-8	CPE/CPEF 20-8	CPE/CPEF 25-5	CPE/CPEF 30-5	CPE/CPEF 32-4	CPE/CPEF 40-4	CPE/CPEF 50-2	CPE/CPEF 100-2
A ₃	143	143	143	143	143	143	143	110
A ₄	465	465	465	465	615	615	615	965
A ₅	298	298	298	298	298	298	298	450
A ₆	178	178	178	178	178	178	178	170
b	A = 98 - 180 / B = 180 - 300							
F	150	150	150	150	150	150	150	103
I	142,5	142,5	142,5	142,5	142,5	142,5	142,5	130
L ₁	209	209	209	209	209	209	209	200
L ₂	262,5	262,5	262,5	262,5	262,5	262,5	262,5	215
L ₃ (VTE)	292	292	292	292	292	292	292	335
L ₃ (VTEF)	296	296	296	296	296	296	296	335
L ₄	213	213	213	213	253	253	253	390
L ₅	312	312	312	312	272	272	272	215
L ₆ (VTE)	342	342	342	342	302	342	342	-
L ₆ (VTEF)	346	346	346	346	306	306	306	-
O	125	125	125	125	125	125	125	150
P (VTE)	197	197	197	197	197	197	197	273
P (VTEF)	205	205	205	205	205	205	205	280
P ₁	229	229	229	229	229	229	229	110
S	b + 70	b + 70	b + 70	b + 70	b + 70	b + 70	b + 70	b + 98
t	27	27	27	27	27	27	27	40
T	97	97	97	97	97	97	97	97

